

mySmart EBDSPIR-24V-VFC

Ceiling Presence Detector



Description

The EBDSPIR series of presence detector switches are designed to provide automatic control of lighting, heating or ventilation loads. They detect movement using a PIR sensor and turn the load on. When an area is no longer occupied the load will switch off after an adjustable time out period.

An optional adjustable internal light sensor provides additional energy saving in lighting applications. When an area is occupied lighting is only switched on when the level of natural light is below a preset level. The EBDSPIR-24V-NL-VFC product does not have the internal light sensor.

When the unit is first powered up the PIR sensor will always detect immediately regardless of whether the room is occupied.

This unit has a 12-24VAC/DC low voltage power supply and provides an isolated voltage free contact output.

Dimensions

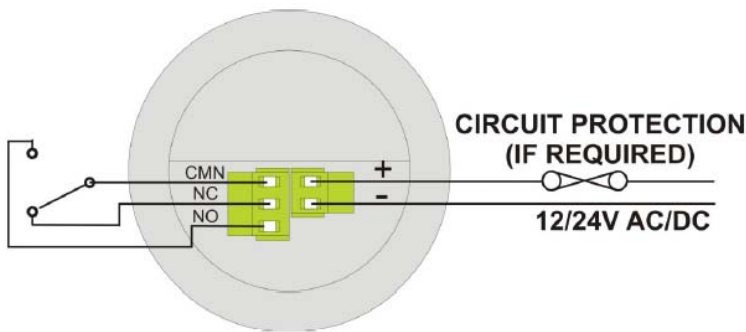
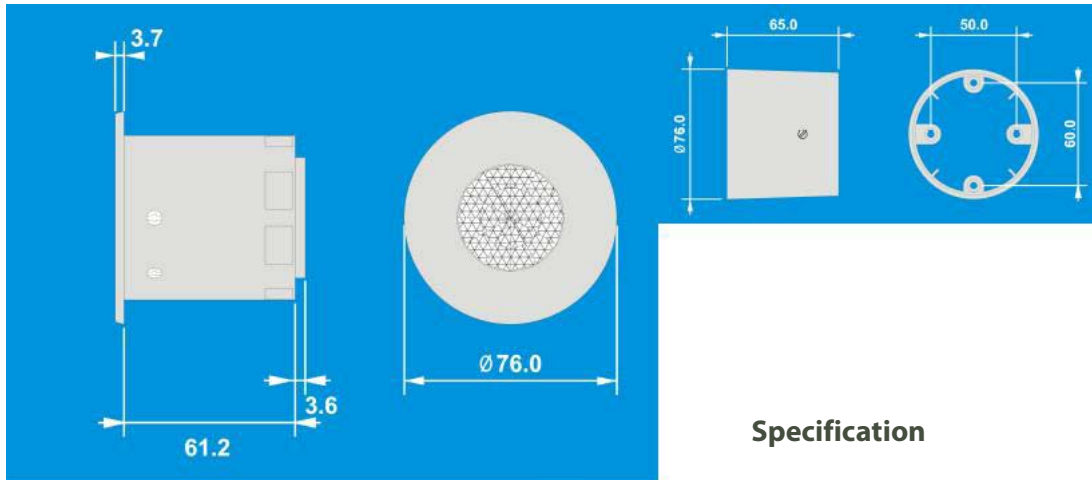

Specification

LOAD

6 Amp resistive load
2 Amp inductive load

SUPPLY VOLTAGE

12-24V AC/DC (+/- 10%)

TIME OUT PERIOD

Adjustable 10s to 30m

LIGHT LEVEL

Light to dark

TERMINAL CAPACITY

2.5 mm²

MATERIAL

Flame retardant ABS, fixing clip
polypropylene

TYPE

Class 2

TEMPERATURE

-10°C to 35°C

CONFORMITY

EMC-89/336/EEC LVD-73/23/EEC

Detection Area

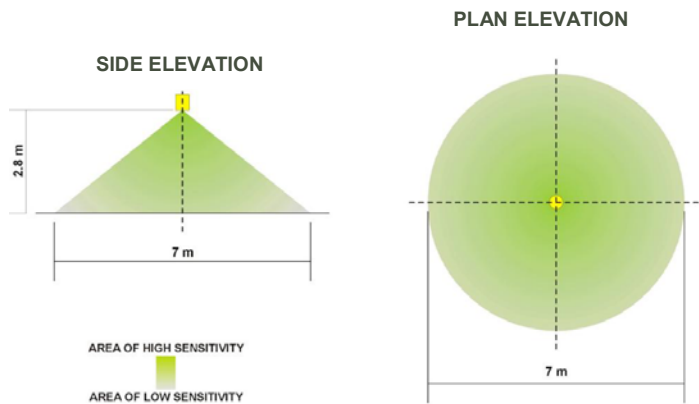

Trouble Shooting

LOAD DOES NOT COME ON

Check to see if the live supply to the circuit is good. Strap across the *L* and *LIVE OUT* terminal to turn the load on. If the supply and wiring are good, for LUX enabled versions, check the LUX level setting. Increase the LUX level setting to allow the controller to turn on at higher ambient natural light level. If the detection range is smaller than expected, check the diagram opposite. Rotating the sensor slightly may improve the range.

LIGHTS DO NOT GO OFF

Ensure that the area is left unoccupied for longer than the selected timer setting. Make sure that the sensor is not adjacent to circulating air, heaters or lamps

Product codes for ordering:

EBDSPIR-24V-VFC Ceiling mounted presence detector with LUX

EBDSPIR-24V-NL-VFC Ceiling mounted presence detector no LUX

DBB Surface mounting back box

Sensor manufactured by: 

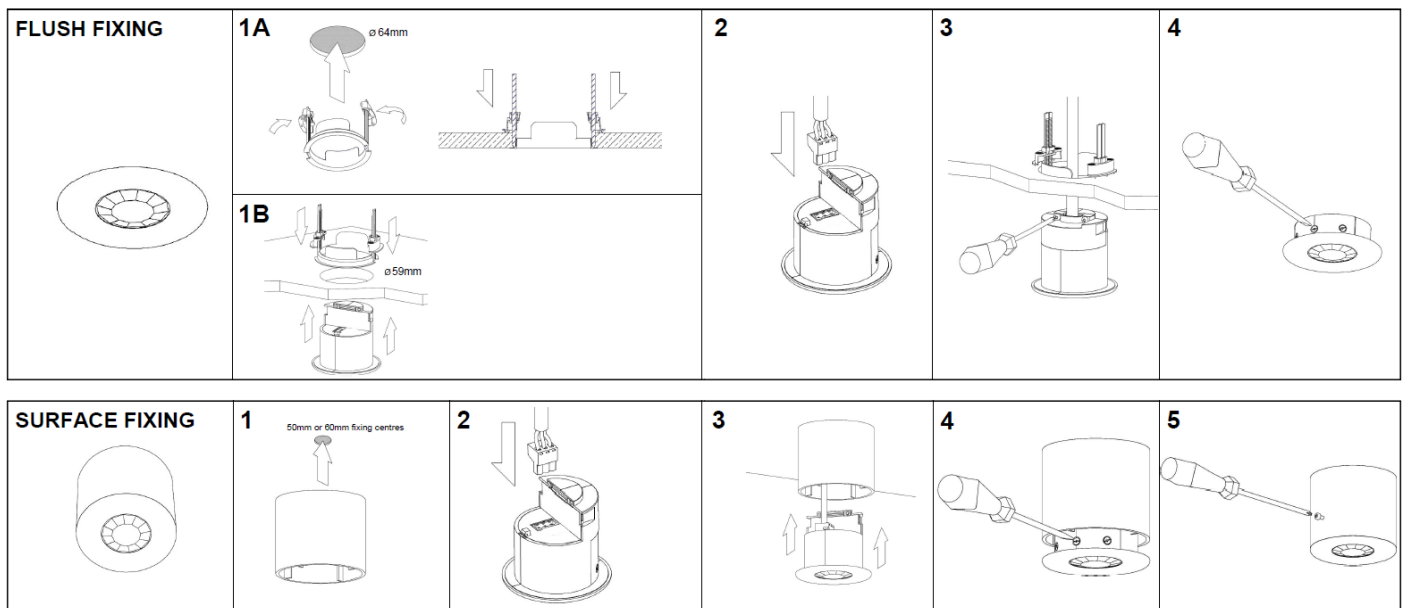

Installation

- ❖ The detector should be sited so that the occupants of the room fall inside the detection pattern shown overleaf, at a recommended height of 2.8m on the ceiling. Note that the lower the sensor is installed the smaller the detection range will be, subject to the parameters shown on the diagram.
- ❖ Avoid direct sunlight entering the sensor.
- ❖ Do not site within 1m of forced air heating or ventilation.
- ❖ Do not site within 1m of any lighting.
- ❖ Do not fix to a vibrating surface.
- ❖ Wire the product using the connector using the diagram on the front page.
- ❖ Mount using one of the three options above.
- ❖ For LUX enabled products, set the LUX level to maximum and the time to minimum.
- ❖ Power the unit up—the load should come on immediately.
- ❖ Vacate the room or remain very still and wait for the load to switch off (should take no more than 2 minutes).
- ❖ Check that the load switches on when movement is detected.
- ❖ To set the final LUX level wait until the level of natural daylight is just enough that lighting is required. Starting with the LUX control fully clock-wise (at minimum), very slowly turn the control anti-clockwise until the lights come on. Note that when the LUX control is at maximum then the lights will **always** come on with occupancy.
- ❖ Set the time required.

NOTE

This device **cannot** be programmed using the DD-LCDHS handheld programmer.



IMPORTANT NOTICE!

This device should be installed by a qualified electrician in accordance with the latest edition of AS3000 general electrical wiring regulations.

www.mysmart.com.au

Ph: 1300 697 627

SYDNEY

MELBOURNE

BRISBANE

CANBERRA

PERTH