

mySmart EBDSPiR-PRM

Presence/Absence Detector



Description

The EBDSPiR-PRM PIR (passive infrared) detector provides automatic control of lighting loads with optional manual control. It can be used on incandescent, fluorescent and compact fluorescent lighting, and has the added benefit of being able to connect an external switch. Two modes of operation are available:

Presence detection:

When movement is detected the load will automatically turn on. When the area is no longer occupied the load will automatically switch off after an adjustable time period. If an external switch is connected, this can override the lights off (after the detection time period has elapsed it will revert to automatic operation). An integral adjustable photocell allows the lights to be kept off if there is sufficient ambient light.

Absence detection:

The load is manually switched on using an external switch. When the area is no longer occupied the load will automatically switch off after the adjustable time period has elapsed. Pressing the switch again during occupancy override the lights off (after the detection time period has elapsed it will revert to automatic operation). An integral infra-red sensor in the unit allows the unit to be programmed using the optional DD-LCDHS programming handset. This gives complete flexibility over many of the operating parameters. Without the handset, manual adjustments can be made to the sensitivity, LUX and time settings using the controls on the rear of the sensor head.

The UHS user handset can be used to change output LUX levels and override the lights on or off.

1. Wire the products using the diagram below.
 2. To switch from more than one position simply wire two or more units in parallel using the Live, Neutral and Switched Live wires only. Please note that this can only be done when using presence detection, and without a manual override switch connected. If absence detection or manual override is required using more than one detector, please use the EBDSPiR-DD detector with a centre biased two way switch.
 3. The detector should be sited so that the occupants of the room fall inside the detection pattern shown in section 5, at a recommended ceiling height of 2.8m. Note that the lower the sensor is installed the smaller the detection range will be, subject to the parameters shown on the diagram.
 4. Avoid direct sunlight entering the sensor.
 5. Do not site within 1m of forced air heating or ventilation.
 6. Do not site within 1m of any lighting.
 7. Do not fix to a vibrating surface.
 8. Mount using one of the three options overleaf.
 9. Connect the sensor via the terminal blocks. Live supply to the **L** terminal; load to the **L/OUT** terminal; Neutral to the **N** terminal on the green terminal block. External switch connections to the switch terminal.
 10. Use a small screwdriver to set the LUX level adjuster fully clockwise, the time to minimum (fully anticlockwise) and the sensitivity to maximum (fully clockwise).
 11. Power the unit up—the load should come on immediately.
 12. Vacate the room or remain very still and wait for the load to switch off (should take no more than 2 minutes).
 13. Check that the load switches on when movement is detected.
 14. The LUX thumbwheel determines the ambient light level at which the lights turn on.
 15. Select the time using the adjuster, fully clockwise is the maximum.
 16. *Using the UHS or UHS3 infra-red handset: the override on button turns the unit on permanently; the override off button turns the unit off permanently; the cancel button cancels the overrides. When an override is selected an LED will flash inside the unit. The UHS handset can also be used to set the LUX levels—see Section 4.3*
- 17. Absence detection**
18. To use absence detection a retractive (momentary) switch must be connected between the 2 terminals on the diagram. Note that this will be switching mains voltage.
 19. The unit ships with presence detection as default. To change to absence detection, press and release the external switch 5 times within the first minute of power up. The LED will turn on solid for 30 seconds to indicate absence mode has been selected.
 20. To change back to presence detection, repeat the above procedure—the LED will flash for 30 seconds to indicate presence mode has been selected.

Note: the above adjustments can also be made using the DD-LCDHS handset instead of the manual adjusters or external switches.

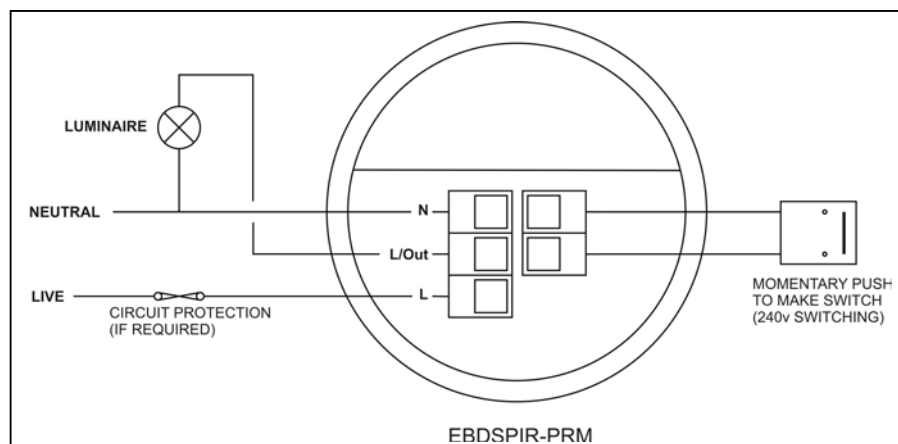

Installation

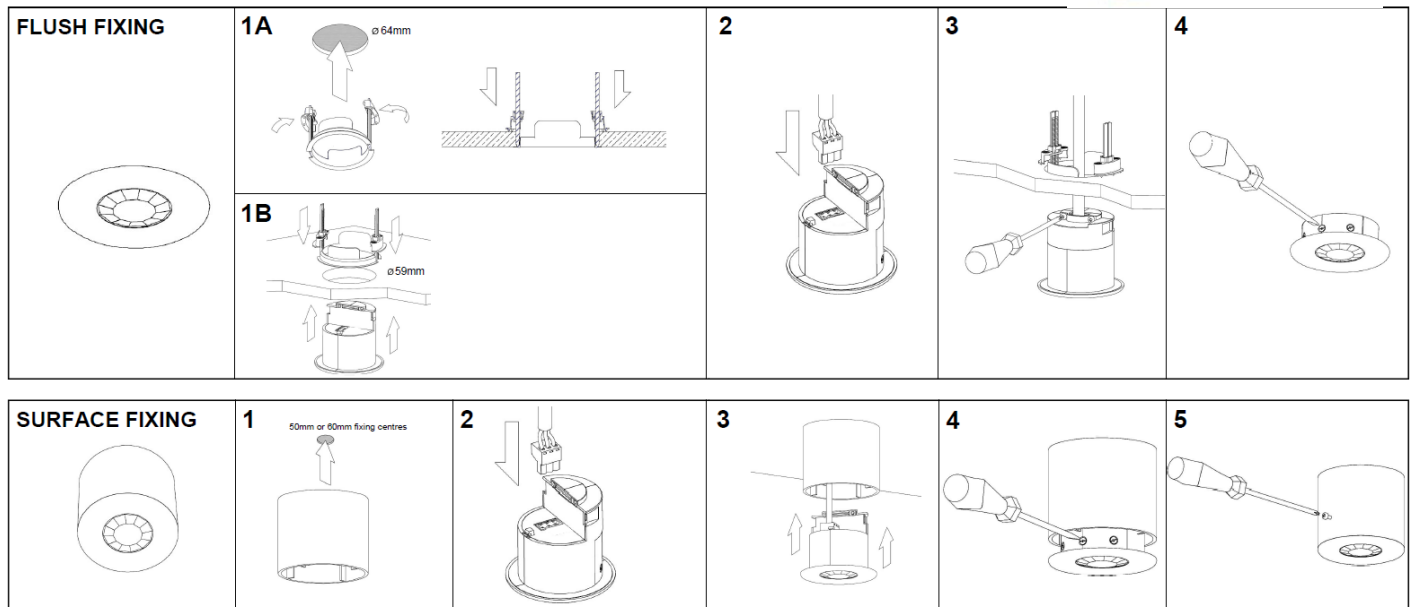

Programming

All the following functions can be programmed using the remote control DD-LCDHS handset:

1. Detector Parameters (factory default in brackets):

- 1.1 Time adjustment** (20 min) 10 seconds to 99 minutes time delay (select 0 for 10 second delay – use for commissioning only).
- 1.2 Sensitivity On** (9) Sensitivity level when the detector is already operational adjustable between 1 (min.) and 9 (max.)
- 1.3 Sensitivity Off** (9) Sensitivity level for switching the detector on – adjustable between 1 (min.) and 9 (max.).
- 1.4 Power Up On** (Y) Select No for a 30 second delay on start up. If Yes is selected, there will be no delay on start up and the detector will always power up detecting.
- 1.5 Walk Test** (N) An LED behind the detector lens will flash to show movement has been detected (use for commissioning).
- 1.6 Disable Detector** (N) Disables detection. In this mode the detector acts as a photocell only. The LUX preset determines the light level at which the output is turned on. The sensitivity preset determines the light level at which the output turns off. The time preset prevents nuisance tripping and in this mode is adjustable between 0-13 minutes.
- 1.7 Factory Default** Restores factory default settings.

2. Switching functions (factory default in brackets):

- 2.1 Presence detection** Auto switch on with detection, auto off after movement ceases (default) and time delay ends.
- 2.2 Absence detection** Manual switch on, auto off after movement ceases and time delay ends.
- 2.3 Switch level on** (9) LUX level setting to prevent the luminaires being switched on if the ambient light level is sufficient (adjustable between 1 and 9). The luminaires will always be switched on at level 9.
- 2.4 Switch level off** (9) LUX level setting to switch the luminaires off during occupancy if the ambient light level goes above the setting (adjustable between 1 and 9). Level 9 will always keep the lights on. This setting can be used for “window row switching”.

3 User Menu

DD-LCDHS user menu or UHS handset functions:

- 3.1 LUX up** Can only be used with the set button—see 3.6.
- 3.2 LUX down** Can only be used with the set button—see 3.6.
- 3.3 Override on** Permanently overrides the luminaire output on.
- 3.4 Override off** Permanently overrides the luminaire output off.
- 3.5 Cancel** Cancels the on or off override, returning the detector to normal operation.
- 3.6 Set** Send before using LUX up or LUX down. The **switch level on** (see 2.3) can then be adjusted using the LUX up or LUX down buttons.

Dimensions

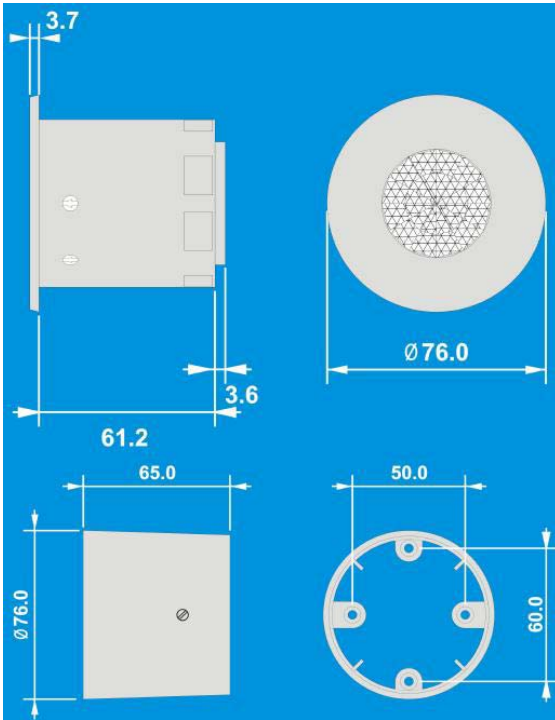

Detection Area

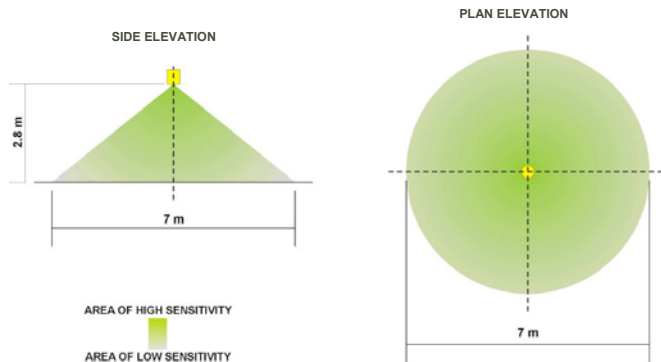

IMPORTANT NOTICE!

This device should be installed by a qualified electrician in accordance with the latest edition of AS3000 general electrical wiring regulations.

NOTE

This sensor can be programmed using the IR remote control programming handset.

Specification

LOAD

10A of lighting and or ventilation including incandescent, fluorescent, compact fluorescent, low voltage (switch primary of transformer)

SUPPLY VOLTAGE

220-240 Volts AC 50 Hz

TIME OUT PERIOD

Adjustable 10 seconds to 99 minutes

LIGHT LEVEL

Light to dark

TERMINAL CAPACITY

2.5mm²

MATERIAL

Flame retardant ABS, fixing clip polypropylene

TYPE

Class 2

TEMPERATURE

-10°C to 35°C

CONFORMITY

EMC-89/336/EEC LVD-73/23/EEC



Trouble Shooting

LOAD DOES NOT COME ON

Check to see if the live supply to the circuit is good. Strap across the *L* and *LIVE OUT* terminal to turn the load on. If the supply and wiring are good, check the LUX level setting. Increase the LUX level setting to allow the controller to turn on at higher ambient natural light level. If the detection range is smaller than expected, check the diagram above. Rotating the sensor slightly may improve the range.

LIGHTS DO NOT GO OFF

Ensure that the area is left unoccupied for longer than the selected timer setting. Make sure that the sensor is not

Product codes for ordering:

EBDSPIR – PRM PIR presence/absence detector

DBB - Surface mounting box

DD-LCDHS - IR remote control programming handset

UHS - IR remote control user handset with lux setting functionality

Sensor manufactured by:

