

mySmart MWS1C

Microwave Presence Detector (ceiling)



Description

The MWS1/C series of microwave presence detector switches are de-signed to provide automatic control of lighting, heating or ventilation loads. The MWS1/C detects movement using a highly sensitive micro-wave detector. This works by emitting low power microwave signals and measuring the reflections as the signals bounce of moving objects. The MWS1/C is optimised to give very sensitive detection in ceiling mount applications.

When movement is detected the load is turned on. When an area is no longer occupied the load will switch off after an adjustable time out period.

An optional internal light sensor provides additional energy saving in lighting applications (MWS1/C/LUX). When an area is occupied lighting is only switched on when the level of natural light is below a preset level.

Dimensions

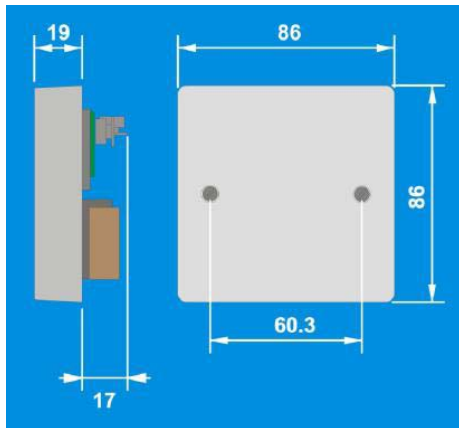

Wiring

Wire the MWS1/C products as in the diagram below.

To switch from more than one position simply wire two or more units in parallel to achieve two way and intermediate switching.

The detector should be sited so that the occupants of the room fall inside the detection pattern shown below, at a recommended height of 2.8m for ceiling mounted sensors. Note that the higher the sensor is installed the shorter the detection range will be.

Do not site within 1m of any lighting or ventilation equipment.

Do not fix to a vibrating surface.

Site as far away as possible from the surface of metal objects.

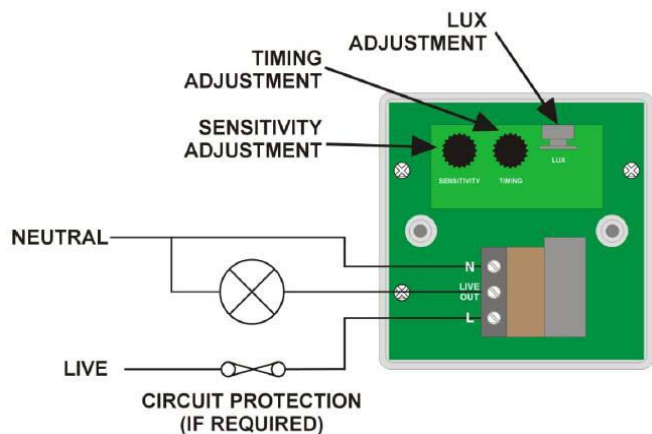

Detection Area



Specification

LOAD

10A of lighting and or ventilation including incandescent, fluorescent, compact fluorescent, low voltage (switch primary of transformer)

SUPPLY VOLTAGE

220-240 Volts AC 50 Hz

TIME OUT PERIOD

Adjustable 15 seconds to 30 minutes.

LIGHT LEVEL

Optional adjustment by thumbwheel light to dark.

FIXING METHOD

Surface fixing 25mm deep plastic surface mount moulded box.
Flush fixing 25mm steel wall box
or 32mm deep cavity wall box.

TERMINAL CAPACITY

4.0mm²

MATERIAL

Flame retardant ABS

TYPE

Class 2

TEMPERATURE

-10°C to 35°C

SAFETY

The microwave radiation emitted by these units is extremely low power. At a distance of > 50mm the power density is <6% of the ANSI IEEE C95.1 – 1991 recommended microwave power density. At a distance of 5mm from the unit it is <84% of recommended power density.

CONFORMITY

EMC-89/336/EEC LVD-73/23/EEC



Trouble Shooting

LOAD DOES NOT COME ON

Check to see if the live supply to the circuit is good. Strap across the *L* and *LIVE OUT* terminal to turn the load on. For LUX versions only, if the supply and wiring are good, check the LUX level setting. Increase the LUX level setting to allow the controller to turn on at higher ambient natural light level.

LIGHTS DO NOT GO OFF

Ensure that the area is left unoccupied for a greater time period than the time out period set using the switch. Make sure that the sensor is not adjacent to vibrating surfaces or objects (e.g. ventilation equipment). The unit may pick up movement through thin partitions or walls. Reduce the sensitivity by turning the thumbwheel anticlockwise.

Installation

Warning. *This device works at mains potential. Be sure to take care when working with electricity.*

1. Make sure the load is connected and in working order.
2. Isolate the mains supply to the circuit at the main consumer unit.
3. Connect the controller via the terminal block. Live supply to the *L* terminal, Neutral to the *N* terminal and the load to the *LIVE OUT* terminal.
4. MWS1/C/LUX only—set the LUX level thumb wheel fully clockwise.
5. Set the time to minimum (fully anticlockwise) and the sensitivity to maximum (fully clockwise).
6. Screw the unit to the wall and switch the mains supply back on at the distribution board.
7. The load should come on immediately.
8. Vacate the room or remain very still and wait for the load to switch off (should take no more than 2 minutes). Check that the load switches on when movement is detected.
9. MWS1/C/LUX only—to set the LUX level wait until the level of natural daylight is just enough that lighting is required. Starting with the LUX thumb wheel fully anti-clockwise, very slowly turn the thumb wheel clockwise until the lights come on. Note that when the LUX thumb wheel is fully clockwise then the lights will **always** come on with occupancy.
10. Select the time out range using the thumb wheel, fully clockwise is the maximum.
11. **Note: on maximum sensitivity this unit is extremely sensitive to movement and may detect through thin walls or partitions. If this causes a problem reduce the sensitivity by turning the thumb wheel anticlockwise.**

Product code for ordering:

MWS1/C Ceiling mounted microwave presence detector

MWS1/C/LUX Ceiling mounted microwave presence detector

with integral light sensor

Sensor manufactured by:



NOTE

This device **cannot** be programmed using the DD-LCDHS handheld programmer.

IMPORTANT NOTICE!

This device should be installed by a qualified electrician in accordance with the latest edition of AS3000 general electrical wiring regulations.



www.mysmart.com.au

Ph: 1300 697 627

SYDNEY

MELBOURNE

BRISBANE

CANBERRA

PERTH